



Duo+

Technical Specification



Duo+ Concept

Flexible

Due to the vertical, self supporting stilts, positioning a Stiltz Home Lift into your home is very flexible. It is free standing so no load-bearing walls are required, and you don't need to worry about window or radiators being in the way. It can tuck into the corner of a room, the stairwell void, on a landing or even in a cupboard!

Space Saving

No visible hoists and no noisy motors. Stiltz Home Lifts' unique technology means the lift runs using discreet wire rope hoists and built-in drive equipment which is all neatly concealed within the lift car roof space. Meaning more space in your home for you, your furniture and your décor.

Simple

Stiltz Home Lifts plug directly into your domestic power sockets. In the event of a power cut, a battery back up will gently return you to the ground until power is restored. To get you from floor to floor, the lift is operated using the intuitive in-car control panel or through remote controls from outside the lift.

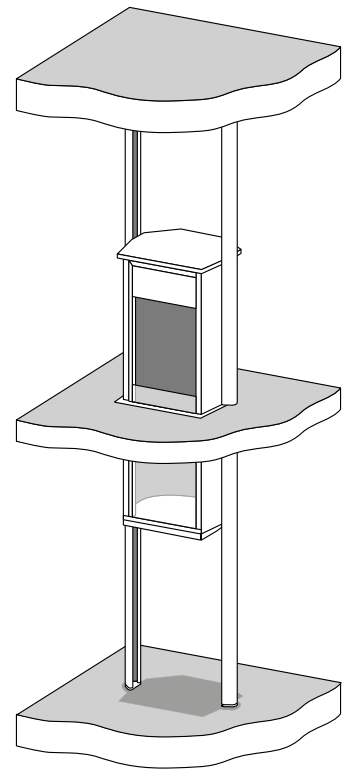

Safety Features



To guarantee safe and comfortable usage at all times, each Stiltz Home Lift is equipped with the following safety features as standard:

1. The half-height door is equipped with a subtle LED light curtain which detects obstacles and gently brings the lift to a stop if the light is crossed. This feature is available as an optional extra with the full height door.
2. The lift will only move from stationary when the lift car door is fully closed.
3. The lift has a built-in braking mechanism for safety and comfort.
4. Sensors positioned to the top and bottom of the lift will automatically stop the lift car immediately an obstruction is detected.
5. In the event of power failure, the lift car can be returned to the lower floor thanks to a battery back up located within the drive unit.
6. A built-in load sensor ensures that the maximum weight limit is not exceeded.
7. The lift car door is secured by a strong locking mechanism which is also very easy to open and close.

Duo+ Benefits



Small Footprint

One of the smallest footprint of any wheelchair lift – covers just 0.8m² surface area.



Quiet

Powered by a quiet electric self-contained motor – no noisy hydraulics.



Fast Installation

Lifts are made up of modular sections – standard installs take just one day.



Power Consumption

Plugs into normal 13 amp power socket – like any other household appliance.



Unique Guide System

Self-supporting structure – two parallel and vertical guides bear load of the lift.



Self Contained Drive System

Housed at the top of the lift, out of sight – no need for external power packs.

Installation Options

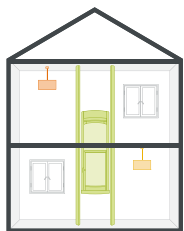

Standard lift

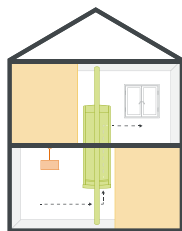

Thru-Car

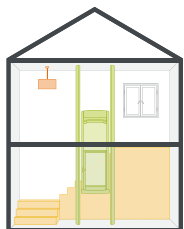

Stairwell void/landing

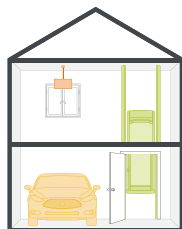

Garage

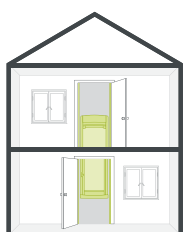

Cupboard Installation

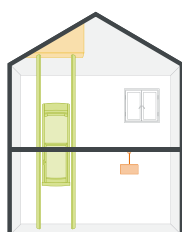

Sloping or vaulted ceilings

Technical Specification

LIFT TYPE	Domestic Personal Home Lift that complies with the Machinery Directive 2006 / 42 / EC
HEIGHT LIMIT	Single floor. With a maximum of 4000mm of travel.
ELECTRICITY	230V socket – Plugs into a normal 13 amp power socket.
LOAD CAPACITY	Max. 170kg / 2 people.
DRIVE	Self-contained wire rope hoist system located in lift car roof space.
DIMENSIONS	1940mm Internal lift car height 790 x 720mm Lift car footprint 1040 x 760mm Overall footprint
CONTROL	Lift is controlled via the control panel and two remote controls. Additional remote controls are available.
LIFT CAR DOOR	1100mm hinged half-height door or full-height door options available. Full height LED light curtain will protect entire door height.
ILLUMINATION	Contemporary ambient lighting with high-quality LED strips.
LIFT HEIGHT	A minimum upper floor ceiling height of 2250mm is required
SPEED	Up to 150mm / sec
ENTRANCE CONFIGURATION	Single door or Thru-car

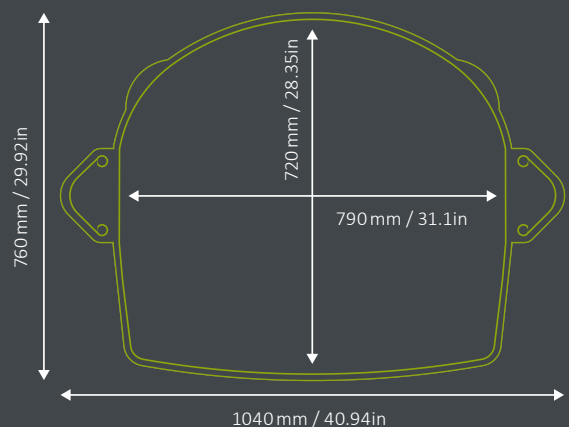

Bentley Mobility Services Ltd



**Unit 19 Highview Business Centre
High Street
Bordon
Hampshire GU35 0AX**

**T: 01420 470730
F: 01420 470731
W: www.bentleymobility.co.uk**

Your approved Stiltz Trade Partner

Committed to providing stylish
and accessible living for all

StiltzTM
The home lift company